

# POPE NUTSCHE FILTER-DRYERS

Pope's nutsche-type high purity filter system allows for solids filtering, washing, reslurrying and drying in a single vessel, reducing process time and worker and environmental exposure.

- ▲ Ideal for processing ultra high purity, pharmaceutical and hazardous materials
- ▲ Available in standard and customizable configurations
- ▲ ASME Section VIII certified
- ▲ Lab, pilot and production units in 2 – 200 liter capacities
- ▲ Portable for multi-application versatility
- ▲ Removable bottom head allows easy cake retrieval
- ▲ Aseptic/sterile designs (cGMP/CIP)
- ▲ Final cake moisture content to 1% is achievable
- ▲ Wide variety of filter media and pore-size offerings



## VESSELS NUTSCHE-TYPE

### POPE NUTSCHE-TYPE BATCH-CAKE FILTERS FOR:

- ▲ Ultra high purity applications
- ▲ Pharmaceuticals
- ▲ Fine chemicals
- ▲ Hazardous substances
- ▲ Biologicals
- ▲ Extracts
- ▲ Many other specialties

Portable 12", 8 gallon  
Nutsche Filter with mixer.  
Stainless steel vessel with  
Teflon-coated interior.  
Shown with optional  
360° rotation capability.



Phone: 262-268-9300

Fax: 262-268-9400

Corporate Capabilities and others – [info@popeinc.com](mailto:info@popeinc.com)

Dewars – [dewars@popeinc.com](mailto:dewars@popeinc.com)

[www.popeinc.com](http://www.popeinc.com)



## Vessel Features:

ASME Section VIII Coded, butt-weld construction with fittings welded both inside and out.

**Materials of Construction:** 316L Stainless Steel. Other alloys including Hastelloy, Titanium, etc. available (any machinable metal)

**Optional Coatings:** Teflon, Halar, Kynar and others

**Ports:** NPT, Sanitary, ANSI Flanged, others as required

**Fittings/Components:** Sight Glass, Inspection, Temperature, Pressure, Feed, Drain, Purge, Vent, Relief, Sampling, Instrumentation and others

**Finish:** 2B mill finish standard; Optional pharmaceutical grade mechanical polishes and electropolishing available

**Agitator:** Pneumatic or Electrical with interchangeable shaft extensions and impellers. Crane Type 8 standard seal

**Heating/Cooling:** ASME jacketing, internal coils or electric heating jackets

## Sizes:

<b>Inside Diameter:</b>	9"	12"	18"	Others
<b>Capacities:</b>	1 – 7 gals	6 – 16 gals	10 – 50 gals	On request
<b>Max. Temp./Pressure:</b>	300°F/175psi	300°F/130psi	On request	On request
<b>Delivery:</b>	10 – 16 weeks after drawing approval			

Vessel and wetted components can be coated as required per application.

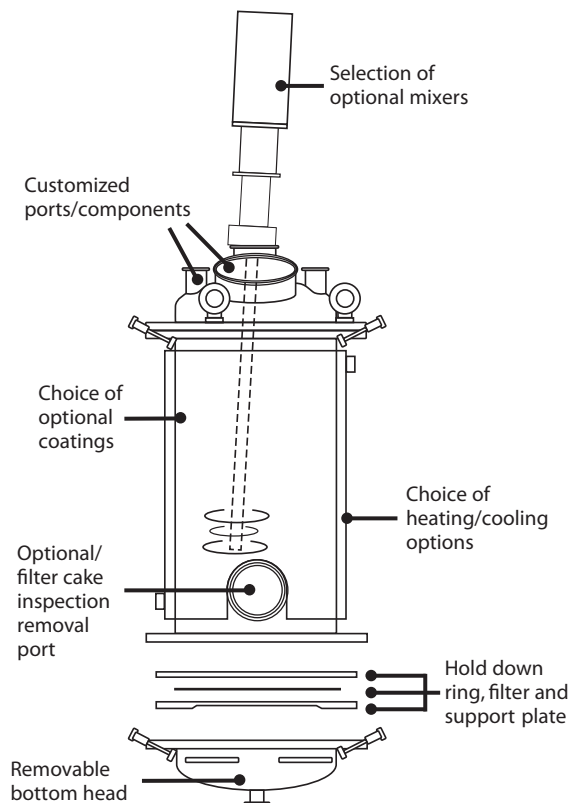

351 North Dekora Woods Boulevard  
P.O. Box 80018  
Saukville, WI 53080 USA

Phone: 262-268-9300

Fax: 262-268-9400

Corporate Capabilities and others – info@popeinc.com

Dewars – dewars@popeinc.com

www.popeinc.com